



Högfors  
GST  
Energy used wisely.

# MIX



## Floor and wall mounted mixing units for heating and cooling

MIX mixing units are high-tech, high-quality, energy-efficient, easy-to-use, and easy-to-understand products that are compatible with nearly all heating systems.



[www.hogforsgst.com](http://www.hogforsgst.com)

## Factors to take into account before selecting a mixing unit:

### Key factors:

- Environmental friendliness and energy efficiency (for example, pumps in energy efficiency class A, insulation)
- Installability
- Ease of use
- Durability of the piping (stainless steel piping: dn20–dn50)
- Comfortable living (no noise problems)
- Maintainability

Selecting the right heating or cooling system for your property requires an expert opinion. Choose your equipment with the help of a designer. Different materials and sizes are also available to order.

## Accessories

### Standard equipment:

- Control valve
- Balancing valves
- Flow measurement devices
- Insulation: Heating / Cooling

### Advantages of MIX mixing units:

- Can be installed on the wall (saving space)
- Mounting accessories will be delivered with the unit, making installation easy
- Pipe material on the secondary side: stainless steel (1.4301) in dn20–dn50 products
- Can be equipped with pumps and regulators, as necessary
- High-quality components that save energy
- Already enclosed in a box and insulated
- Available for right-handed and left-handed operators

- Circulation pump (pumps Grundfoss/Wilo/Kolmeks)
- Thermometers (embedded)
- Shut-off valves and drain valves
- Box

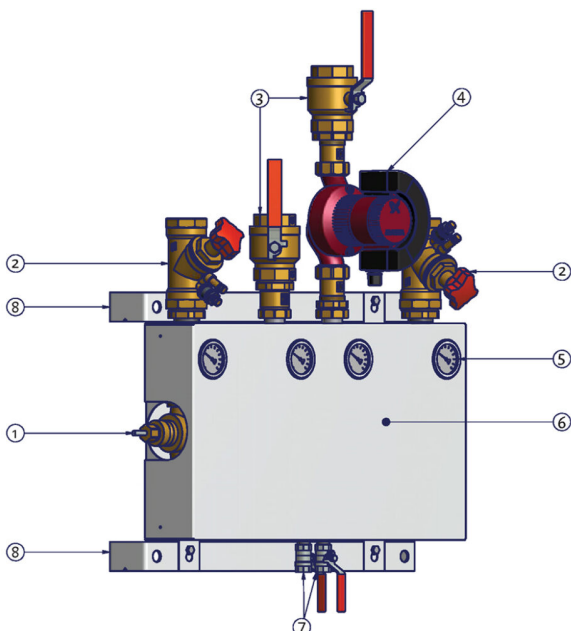

## MIX DN20–DN50

1. Control valve
2. Balancing valve (2 pcs)
3. Ball valve (2 pcs)
4. Pump

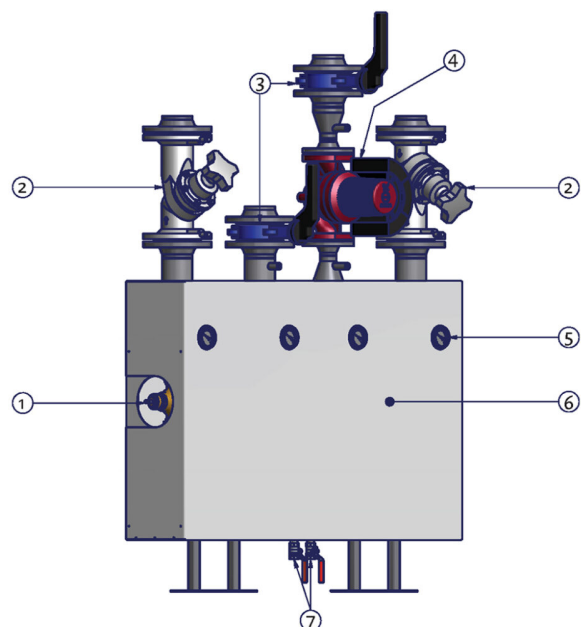

## U-Shunt DN65–DN100

1. Control valve
2. Balancing valve (2 pcs)
3. Butterfly valve (2 pcs)
4. Pump

5. Thermometer (4 pcs)
6. Non-return valve (inside the box)
7. Drain valve (2 pcs)
8. Wall mounting bracket (2 pcs)

5. Thermometer (4 pcs)
6. Non-return valve (inside the box)
7. Drain valve (2 pcs)

### MIX DN20-DN50

	DN20	DN25	DN32	DN40	DN50
A	700	700	850	850	850
B	460	460	600	600	600
C	50	50	75	75	75
D	200	200	230	230	230
E	200	200	240	240	240
F	170	170	200	200	200
G *	400	400	425	450	470
B	460	460	577	577	577
I	125	125	125	125	125
J *	310	310	310	310	310
Weight (kg) ~	37	42	57	62	67

\* The measurement depends on the pump being used.  
The measurement indicated in the table is for the Grundfos Magna 25-100 pump.

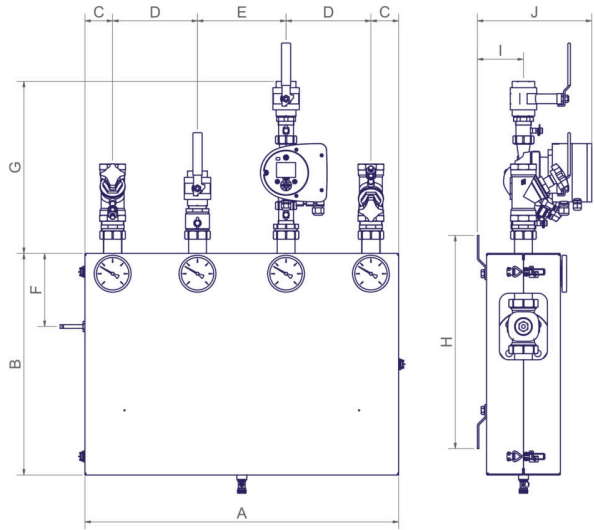

### MIX DN65-DN100

	DN65	DN80	DN100
A	1300	1300	1450
B	800	800	1150
C	125	125	125
D	350	350	400
E	350	350	400
F	325	325	325
G *	795	815	895
B	190	190	190
I	120	120	140
J *	420	420	450
Weight (kg) ~	190	155	280

\* The measurement depends on the pump being used.  
The measurement indicated in the table is for the Grundfos Magna340-120F pump.

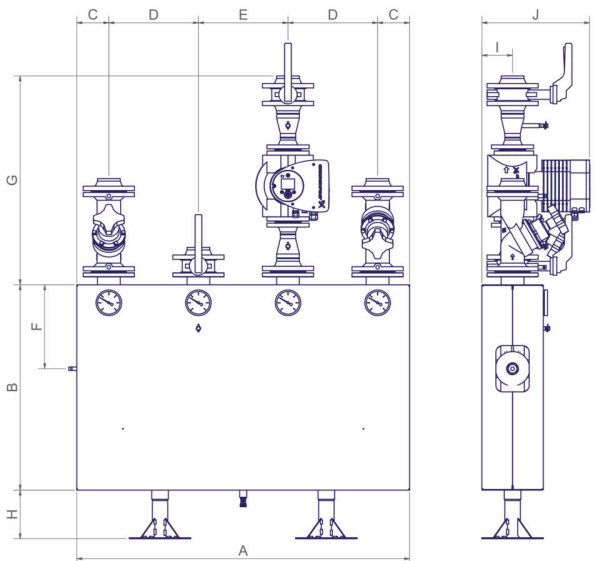

## Circuit diagrams

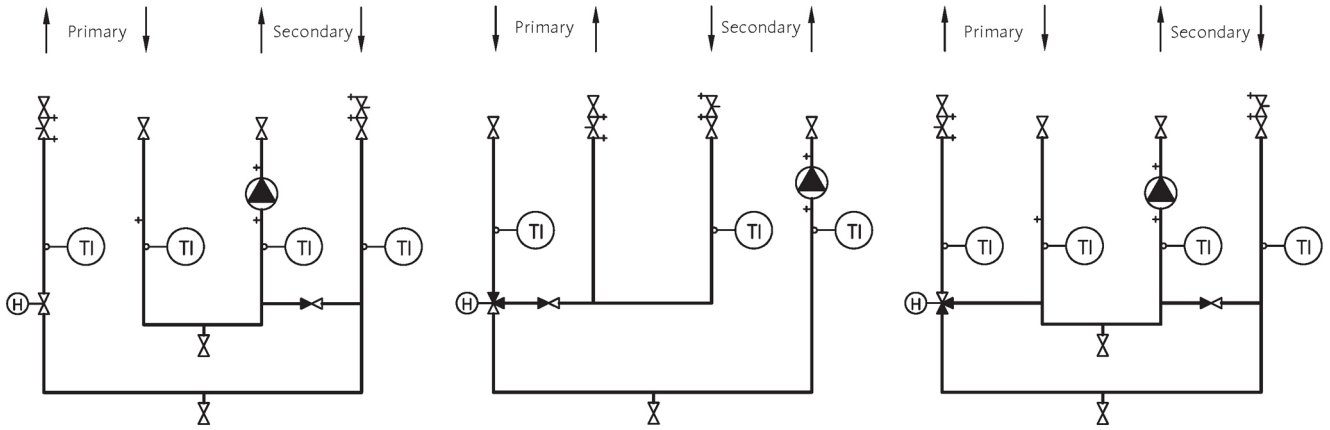

### Long warranty, short delivery time

Your Mix products always have a competitive warranty. Exact terms of warranty are market based, fulfilling however all area requirements and standards. All terms are stated in HögforsGST warranty conditions.

### MIX 32 / 50U-H-2-L

**MIX** = Product family name

**32** = Pipe size, primary (DN)

**50** = Pipe size, secondary (DN)

**U** = Model, connection type

**H** = Purpose: H = Heating, C = Cooling

**2** = Control valve type: 2 = 2-Way, 3 = 3-Way

**L** = Primary connection side: L = left, R = right

## HögforsGST International expertise in heating systems

HögforsGST specialises in the manufacture, sale and marketing of high-quality heating systems. The company has solid expertise in heating systems, both domestically and in export markets.

Our expertise is based on our experience in production, serial manufacture, mass customisation, and project production, as well as our knowledge of the acquisition channels in the HVAC industry and logistics, both in Finland and abroad.

Our operations are based on extensive investigation into the operating conditions of the market, customer orientation and reliability. We are equally uncompromising in terms of our high-quality products and services.

HögforsGST International heating expertise HögforsGST Oy specialises in the manufacture, sales and marketing of high-quality heating systems. The company's strong expertise on heating systems reaches beyond Finland. Our competence is based on our in-depth experience in production, line manufacturing, high-volume customisation and project production as well as familiarity with the HVAC acquisition channels and logistics both in Finland and abroad. Our business has always been based on determining sufficient operating requirements on the market, customer-orientation and reliability. Equally important is our uncompromising approach with the high quality of our products and services. We reserve the right to make changes.